

ATTENZIONE - ATTENTION - ACHTUNG

- Per lo smontaggio degli utensili utilizzare sempre la chiave di contrasto come indicato nel manuale d'uso.
- For disassembly of the tools use always the contrast key as mentioned in the user instructions.
- Fuer das Abmontieren der Werkzeuge immer den Gegenschlüssel benutzen wie in der Bedienungsanleitung erwaeht.

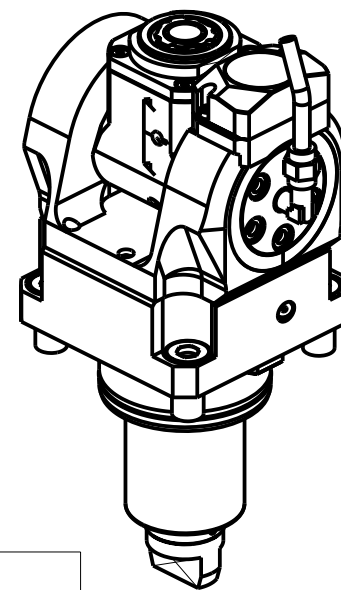

Cod. MT	Mandrino Spindle Spindel	I	RPM	Coppia Max Max Torque Max Drehmoment	Reversibile lato mandrino/contromandrino Reversible sub/main spindle side Umkehrbare Spindel-seite/ Gegenspindel-seite	Lubrificazione int. Coolant through Innenkuehlung	Lubrificazione est. Ext. coolant Ausseinkuehlung	CHIAVI INCLUDE Keys included Schluessel inbegriffen			
								CHUB36	CHUB22	CHTAER20ZC	CHESL08
DW01945120	ERA20	1:1	6000	30Nm	X	-	X	CHUB36	CHUB22	CHTAER20ZC	CHESL08
DW01945220	ERA20	1:1	6000	30Nm	X	P=70bar	X	CHUB36	CHUB22	CHTAER20ZC	CHESL08

YCM
MOD: BTX250SY - NT2000/2500 12 STAZIONI

MODULO MOTORIZZATO ORIENTABILE ±90° CON NONIO DIGITALE H=72mm
±90° adjustable angle driven tool with digital display H=72mm
Angetriebenes Werkzeug schwenkbar ±90° mit digital display H=72mm

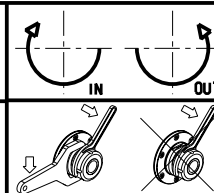

M.T. srl
Via Casino Albini 480
Tel. 0541/956034-957884
Fax 0541/956341
47842 S. GIOVANNI IN M. (RN)
e-mail: mtma@mtmarchetti.com
http://www.mtmarchetti.com



YCM335-2-01

Subject to change without notice.

03/2024