

ATTENZIONE - ATTENTION - ACHTUNG

- VERIFICARE LE MISURE DI INGOMBRO PER POSSIBILE INTERFERENZA SU ALCUNI MODELLI DI MACCHINE
- Please check the overall sizes for possible interferences on some machine models
- Bitte überprüfen sie das ausmass um mögliche interferenzen auf einigen maschinen modellen zu vermeiden

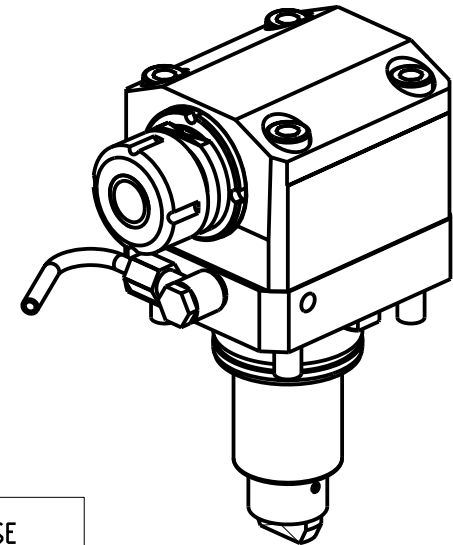
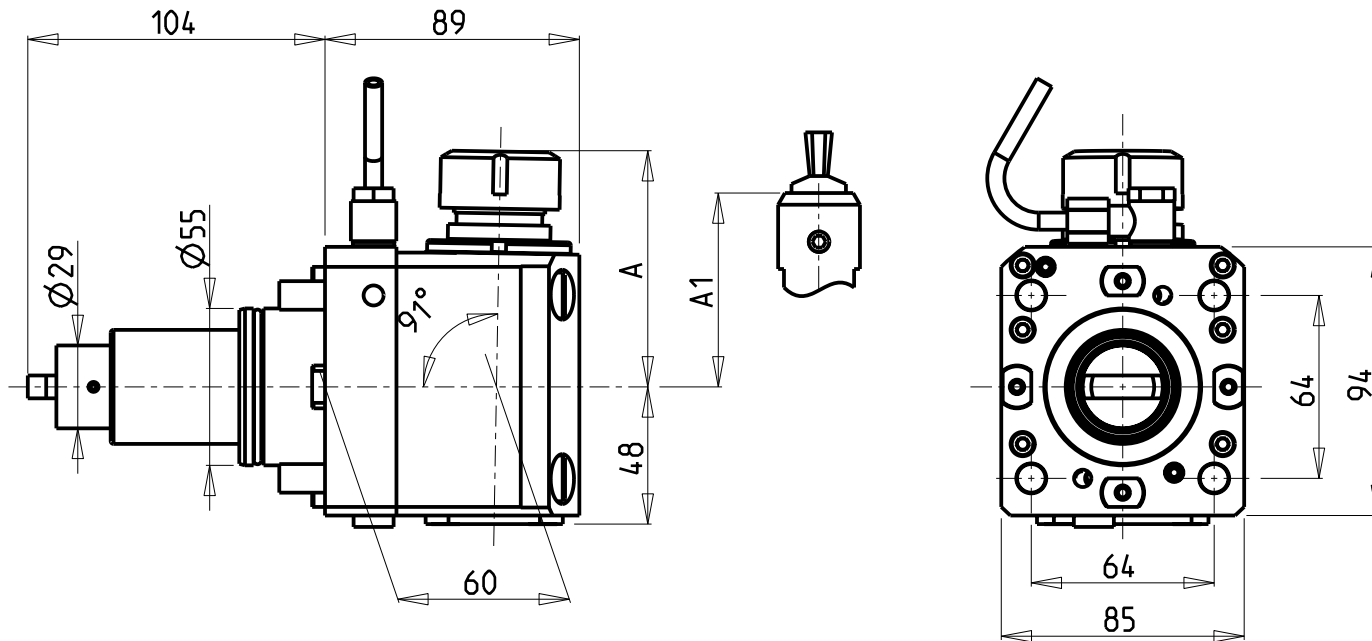

Cod. MT	Mandrino Spindle Spindel	I	RPM	Coppia Max Max Torque Max Drehmoment	Reversibile lato mandrino/contromandrino Reversible sub/main spindle side Umkehrbare Spindel-seite/ Gegenspindel-seite	Lubrificazione est. Ext. coolant Auslenkuehlung	A	A1	CHIAVI NON INCLUSE Keys not included Schluessel nicht einbegriffen	
0319125	ER25	1:1	6000	50Nm	X	X	82.35	-	CHSTER25	CHUB36 o 0100000
0319108	WELDON 8	1:1	6000	50Nm	X	X	-	76.5		
0319110	WELDON 10	1:1	6000	50Nm	X	X	-	76.5		
0319112	WELDON 12	1:1	6000	50Nm	X	X	-	76.5		
0319116	WELDON 16	1:1	6000	50Nm	X	X	-	73.5		

VICTOR
 MOD: VTURN-A16/A20/A200 CM/SCM/YCM/YSCM - VTURN-Q200 - VTURN-NP20CM

MODULO MOTORIZZATO ASSIALE PER POLIGONATURA INTERNA H=60mm
 Axial driven tool for internal polygon-making H=60mm
 Axial angetriebenes Werkzeug fuer interne Facettierung H=60mm

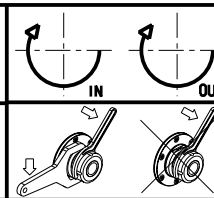

M.T. srl
 Via Casino Albini 480
 Tel. 0541/956034-957884
 Fax 0541/956341
 47842 S. GIOVANNI IN M. (RN)
 e-mail: mtma@mtmarchetti.com
 http://www.mtmarchetti.com

MT

VCT230-1-10

Subject to change without notice.