

### ATTENZIONE - ATTENTION - ACHTUNG

- Per lo smontaggio degli utensili utilizzare sempre la chiave di contrasto come indicato nel manuale d'uso.
- For disassembly of the tools use always the contrast key as mentioned in the user instructions.
- Fuer das Abmontieren der Werkzeuge immer den Gegenschlüssel benutzen wie in der Bedienungsanleitung erwaeht.

### ATTENZIONE - ATTENTION - ACHTUNG

- VERIFICARE LE MISURE DI INGOMBRO PER POSSIBILE INTERFERENZA SU ALCUNI MODELLI DI MACCHINE
- Please check the overall sizes for possible interferences on some machine models
- Bitte überprüfen sie das ausmass um mögliche interferenzen auf einigen maschinen modellen zu vermeiden

### ATTENZIONE - ATTENTION - ACHTUNG

- PRIMA DI UTILIZZARE IL MOTORIZZATO CONSULTARE LE ISTRUZIONI ALLEGATE!
- BEFORE USING THE DRIVEN TOOL, PLEASE CHECK THE ENCLOSED INSTRUCTION SHEET!
- VOR DER BENUTZUNG DES ANGETRIEBENEN WERKZEUGES, DIE BEILIEGENDEN INSTRUKTIONEN DURCHLESEN!

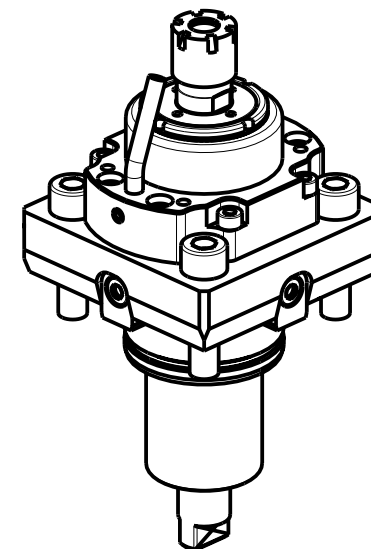

| Cod. MT     | Mandrino Spindle Spindel | I       | RPM   | Coppia Max Max Torque Max Drehmoment | Lubrificazione int. Coolant through Innenkuehlung | Lubrificazione est. Ext. coolant Ausssenkuehlung | A      | CHIAVI INCLUSE<br>Keys included<br>Schlüssel einbegriffen |        |
|-------------|--------------------------|---------|-------|--------------------------------------|---|--|--------|---|--------|
| DW 00600116 | ER16                     | 1:5.625 | 22500 | 6Nm                                  |   | X  | 95.25  | CHMNER16  | CHUB17 |
| DW 00600111 | ER11                     | 1:5.625 | 22500 | 6Nm                                  | P=30bar   | X  | 107.45 | CHMNER11  | CHUB11 |

VICTOR

MOD: VTURN-A16/A20/A200 CM/SCM/YCM/YSCM - VTURN-Q200 - VTURN-NP20CM - VTURN-S20CM

MODULO MOTORIZZATO RADIALE MOLTIPLICATO I=1:5.625

Radial geared-up I=1:5.625 driven tool

Radial angetriebenes Werkzeug uebersetzt I=1:5.625

Subject to change without notice.

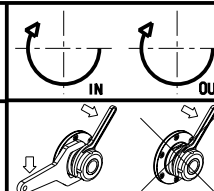

**M.T. srl**

Via Casino Albini 480  
Tel. 0541/956034-957884  
Fax 0541/956341  
47842 S. GIOVANNI IN M. (RN)  
e-mail: mtma@mtmarchetti.com  
http://www.mtmarchetti.com



VCT060-1-00