

-LA FUNZIONE DI POLIGONATURA/DENTATURA DEVE ESSERE INSTALLATA SULLA MACCHINA
 -POLYGON CUTTING/GEAR HOBBING FUNCTION MUST BE INSTALLED ON THE MACHINE
 -DIE FUNKTION FÜR POLYGON-BZW. VERZÄHNUNGSFRÄSEN MUSS AUF DER MASCHINE FREIGESCHALTET WERDEN

**TORRETTE ASSIALI
 AXIAL TURRETS
 AXIAL REVOLVER**

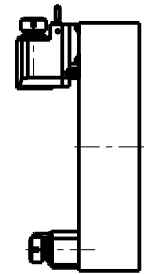

INCLINAZIONE
 REGOLABILE ±20°

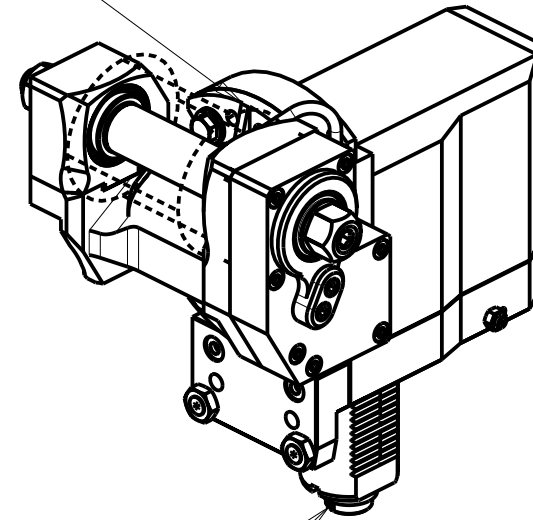

DIN 5480

PER ALBERI E DISTANZIALI VEDI PAG. TBL250-1-00
 FOR SHAFT END SPACER SEE PAGE TBL250-1-00
 FUER DORN UND ABSTANDSSTUECK SEITE TBL250-1-00

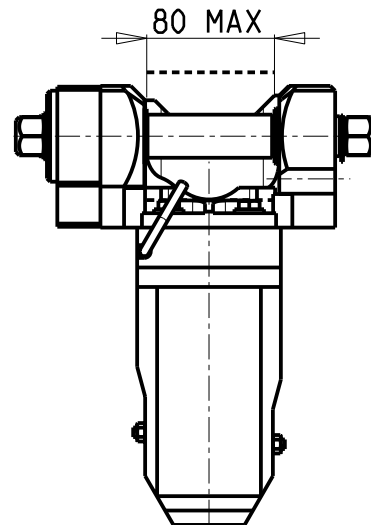
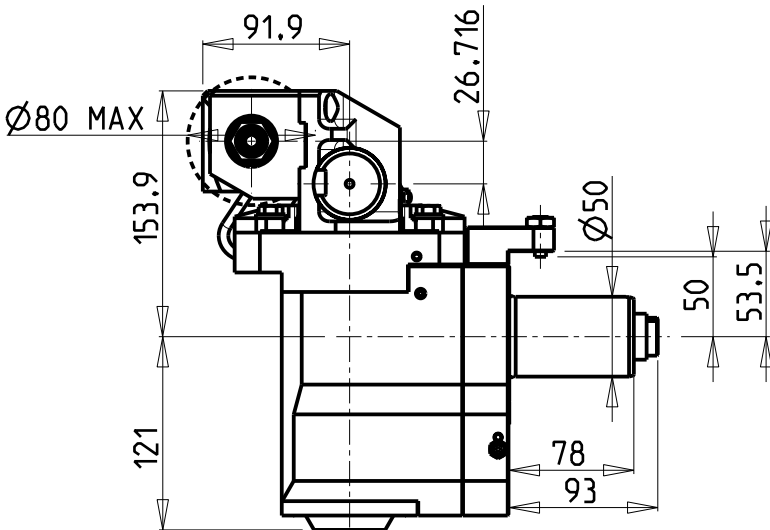

Cod. MT		I	RPM	Coppia Max Max Torque Max Drehmoment	Lubrificazione est. Ext. coolant Aussehenkuehlung	D (mm)	D (Inch)	CHIAVI INCLUSE Keys included Schlüssel einbegriffen		
versione dx right version version rechts	versione sx left version version links							CHUB24	CHUB13	CHESL08
SAU0011150	SAU0013150	1:1	6000	60Nm	X	16-22-27-32	3/4"-1"-1 1/4"	CHUB24	CHUB13	CHESL08
SAU0012150	SAU0014150	2:1	3000	80Nm	X	16-22-27-32	3/4"-1"-1 1/4"	CHUB24	CHUB13	CHESL08

DOTAZIONI - SUPPLIED WITH - AUSSTATTUNG	
mm / inch	
	- N°1 ALBERO + DISTANZIALI - N°1 SHAFT + SPACER - N°1 DORN + ABSTANDSSTUECK

SAUTER
VDI 50

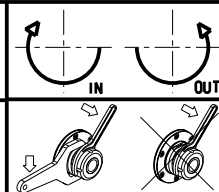

M.T. srl
 Via Casino Albini 480
 Tel. 0541/956034-957884
 Fax 0541/956341
 47842 S. GIOVANNI IN M. (RN)
 e-mail: mtma@mtmarchetti.com
 http://www.mtmarchetti.com



MODULO MOTORIZZATO PORTACREATORE VDI50 DIN 5480
 Driven gear hobber VDI50 DIN 5480
 Angetriebenes Zahnradwaeltzraes-Werkzeug VDI50 DIN 5480

SAU340-4-00

Subject to change without notice.

03/2024