

TORRETTE ASSIALI
AXIAL TURRETS
AXIAL REVOLVER

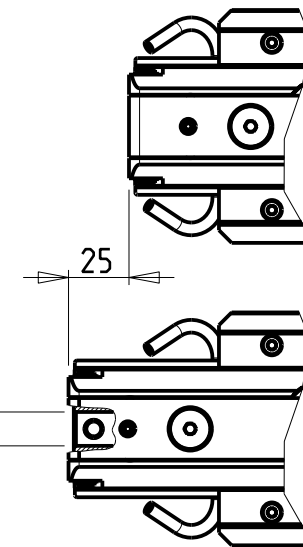
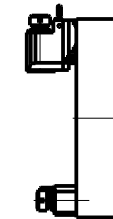

DOTAZIONI - SUPPLIED WITH - AUSSTATTUNG

N°1 Boccola di riduz. Ø16-Ø12 e N°1 Boccola di riduz. Ø16-Ø10
 N°1 Reduction bush Ø16-Ø12 and N°1 Reduction bush Ø16-Ø10
 N°1 Reduzierbuchsen Ø16-Ø12 und N°1 Reduzierbuchsen Ø16-Ø10

PER UTENSILI STOZZATORI VEDI PAG. TBL400-1-00
 FOR DRIVEN SLOTTING TOOL CUTTING-TOOLS SEE PAGE TBL400-1-00
 FÜR NUTENSTOSS-WERKZEUG SCHNEIDWERKZEUGE SIEHE SEITE TBL400-1-00

Cod. MT	I	RPM	Lubr. esterna Ext. coolant Ausßenkuehlung
SAU1012200	4:1	2400	X

SAUTER
 VDI 40
 MODULO MOTORIZZATO STOZZATORE CORSA 25mm VDI40 DIN 5480
 Slotting driven tool 25mm stroke VDI40 DIN 5480
 Keilnutenstossmaschine 25mm Hub VDI40 DIN 5480

M.T. srl
 Via Casino Albini 480
 Tel. 0541/956034-957884
 Fax 0541/956341
 47842 S. GIOVANNI IN M. (RN)
 e-mail: mtma@tmarchetti.com
 http://www.tmmarchetti.com

SAU360-3-31

Subject to change without notice.