

DIN 5480

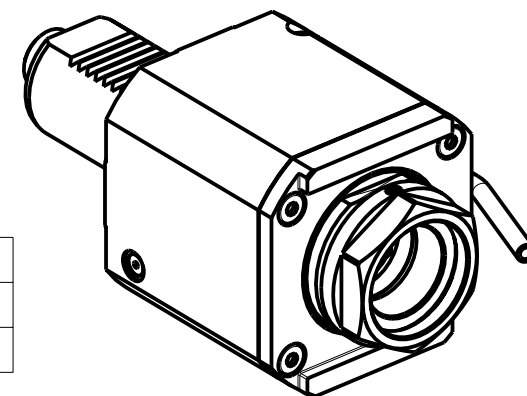

- Chiave inclusa
- Key included
- Schuessel inbegriffen

PER PORTAUTENSILI MODULARI MTSK-40 VEDI PAG. TBL300-1-40  
 FOR MTSK-40 QUICK CHANGE TOOLHOLDERS CLAMPINGS SEE PAGE TBL300-1-40  
 FUER MTSK-40 MODULARE WERKZEUGAUFNAHMEN SIEHE SEITE TBL300-1-40

Cod. MT	Mandrino Spindle Spindel	i	RPM	Coppia Max Max Torque Max Drehmoment	Lubrificazione int. Coolant through Innenkuehlung	Lubrificazione est. Ext. coolant Aussenkuehlung	CHIAVI NON INCLUSE Keys not included Schuessel nicht einbegriffen	
SAU0550140	MTSK-40	1:1	6000	70Nm	-	X	CHUB46	OKU0650004 *
SAU0551240	MTSK-40	1:1	6000	70Nm	P=70bar	X	CHUB46	OKU0650004 *

SAUTER  
VDI 40

MODULO MOTORIZZATO ASSIALE MTSK VDI40 DIN 5480  
 Axial MTSK driven tool VDI40 DIN 5480  
 Axial MTSK angetriebenes Werkzeug VDI40 DIN 5480

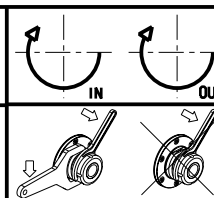

**M.T. srl**  
 Via Casino Albini 480  
 Tel. 0541/956034-957884  
 Fax 0541/956341  
 47842 S. GIOVANNI IN M. (RN)  
 e-mail: mtma@mtmarchetti.com  
 http://www.mtmarchetti.com



SAU017-3-00-K

Subject to change without notice.

09/2024