

versione dx
right version
version rechts

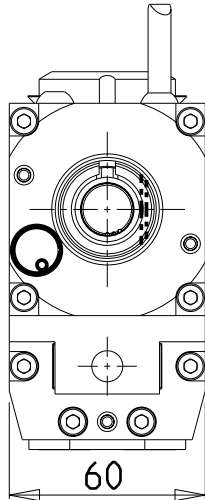

versione sx
left version
version links

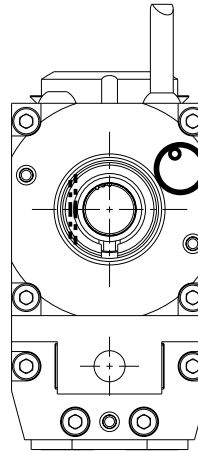

versione universale
universal version
universal version

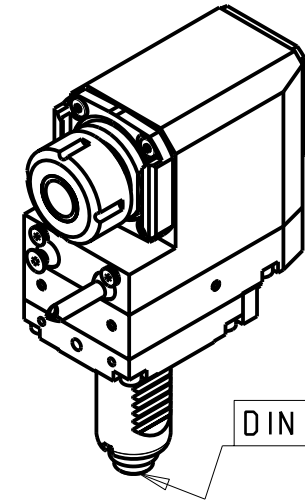
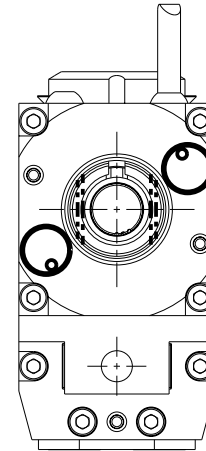

DIN 5480

- Chiave inclusa
- Key included
- Schlüssel inbegriffen

Cod. MT			Mandrino Spindle Spindel	I	RPM	Coppia Max Max Torque Max Drehmoment	Lubrificazione int. Coolant through Innenkuehlung	Lubrificazione est. Ext. coolant Aussenkuehlung	A1	A2	B	CHIAVI NON INCLUDE Keys not included Schlüssel nicht einbegriffen		
versione dx right version version rechts	versione sx left version version links	versione universale universal version universal version												
SAU0130120	SAU0131120	SAU0132120	ER20	1:1	6000	32Nm	-	X	41.16	-	73.5	-	CHSTER20	OKU0290009 ■
SAU0130220	SAU0131220	SAU0132220	ER20	1:1	6000	32Nm	P=70bar	X	41.16	-	83.5	-	CHSTER20	OKU0290009 ■
SAU0130320	SAU0131320	SAU0132320	ERA20	1:1	6000	32Nm	-	X	24.5	-	73.5	CHUB22	CHTAER20ZC ■	OKU0290009 ■
SAU0130420	SAU0131420	SAU0132420	ERA20	1:1	6000	32Nm	P=70bar	X	24.5	-	83.5	CHUB22	CHTAER20ZC ■	OKU0290009 ■
SAU0130125	SAU0131125	SAU0132125	ER25	1:1	6000	32Nm	-	X	42.16	-	73.5	-	CHSTER25	OKU0290009 ■
SAU0130225	SAU0131225	SAU0132225	ER25	1:1	6000	32Nm	P=70bar	X	42.16	-	83.5	-	CHSTER25	OKU0290009 ■
SAU0130325	SAU0131325	SAU0132325	ERA25	1:1	6000	32Nm	-	X	28.5	-	73.5	CHUB27	CHTAER25ZC ■	OKU0290009 ■
SAU0130425	SAU0131425	SAU0132425	ERA25	1:1	6000	32Nm	P=70bar	X	28.5	-	83.5	CHUB27	CHTAER25ZC ■	OKU0290009 ■
SAU0130516	SAU0131516	SAU0132516	WELDON16	1:1	6000	32Nm	-	X	-	27.5	73.5	-	-	-

SAUTER
VDI 30

MODULO MOTORIZZATO RADIALE ARRETRATO VDI30 DIN 5480 H=85mm
Radial rear-set driven tool VDI30 DIN 5480 H=85mm
Radial angetriebenes Werkzeug zurueckversetzt VDI30 DIN 5480 H=85mm

Subject to change without notice.

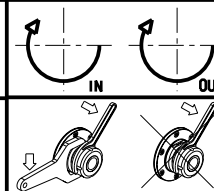

M.T. srl

Via Casino Albini 480
Tel. 0541/956034-957884
Fax 0541/956341
47842 S. GIOVANNI IN M. (RN)
e-mail: mtma@mtmarchetti.com
http://www.mtmarchetti.com



SAU018-2-70