

ATTENZIONE - ATTENTION - ACHTUNG

- Per lo smontaggio degli utensili utilizzare sempre la chiave di contrasto come indicato nel manuale d'uso.
- For disassembly of the tools use always the contrast key as mentioned in the user instructions.
- Fuer das Abmontieren der Werkzeuge immer den Gegenschlüssel benutzen wie in der Bedienungsanleitung erwaeht.

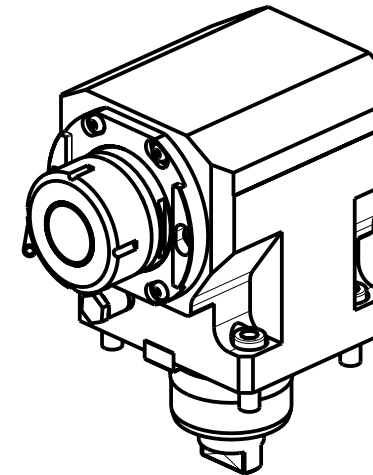
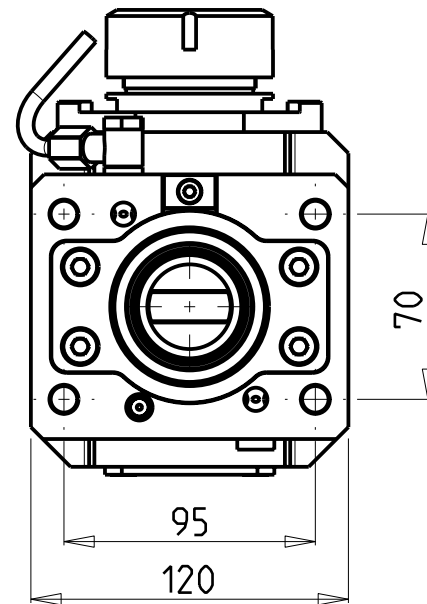
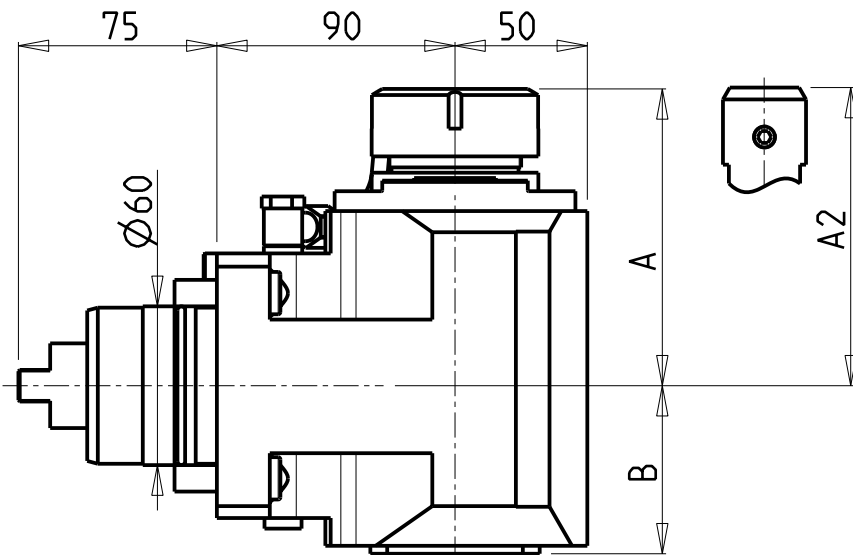

- Chiave inclusa
- Key included
- Schlüssel inbegriffen

Cod. MT	Mandrino Spindel Spindel	I	RPM	Coppia Max Max Torque Max Drehmoment	Reversibile lato mandrino/contromandrino Reversible sub/main spindle side Umkehrbare Spindel-seite/Gegenspindel-seite	Lubr.interna Coolant through Innenkuehlung	Lubr.esterna Ext. coolant Aussenkuehlung	A	A2	B	CHIAVI NON INCLUDE Keys not included Schluessel nicht einbegriffen	
TKW 0160140	ER40	1:1	3500	90Nm	X	-	X	112.16	-	63.5	CHSTER40	OKU0430007 •
TKW 0160240	ER40	1:1	3500	90Nm	X	P=70bar	X	112.16	-	76	CHSTER40	OKU0430007 •
TKW 0160532	WELDON 32	1:1	3500	90Nm	X	-	X	-	107	63.5	-	-
TKW 0160632	WELDON 32	1:1	3500	90Nm	X	P=70bar	X	-	107	76	-	-

TAKISAWA
 MOD: NEX315/715 - LS800M - VTL750/760M - LA350/450M - LA250YS 12ST. - NX2500 12ST.

MODULO MOTORIZZATO ASSIALE
 Axial driven tool
 Axial angetriebenes Werkzeug

Subject to change without notice.

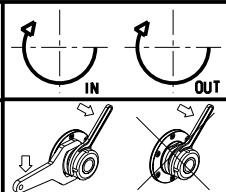

M.T. srl
 Via Casino Albini 480
 Tel. 0541/956034-957884
 Fax 0541/956341
 47842 S. GIOVANNI IN M. (RN)
 e-mail: mtma@mtmarchetti.com
 http://www.mtmarchetti.com



TKW 150-4-10