

PER LAVORAZIONI INTERNE  
SU FORI Ø120 MINIMO

For machining internal  
holes with Ø120 min. hole

Fuer interne Bearbeitungen  
am Loch minimum Ø120

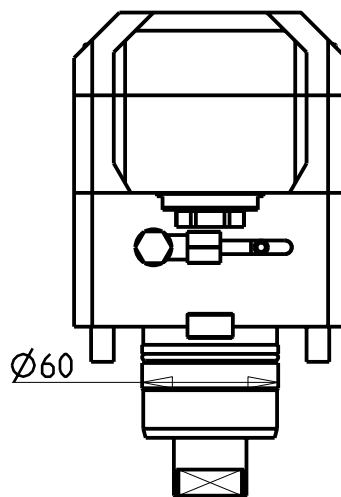

**ATTENZIONE - ATTENTION - ACHTUNG**

- Per lo smontaggio degli utensili utilizzare sempre la chiave di contrasto come indicato nel manuale d'uso.
- For disassembly of the tools use always the contrast key as mentioned in the user instructions.
- Fuer das Abmontieren der Werkzeuge immer den Gegenschlüssel benutzen wie in der Bedienungsanleitung erwaehnt.

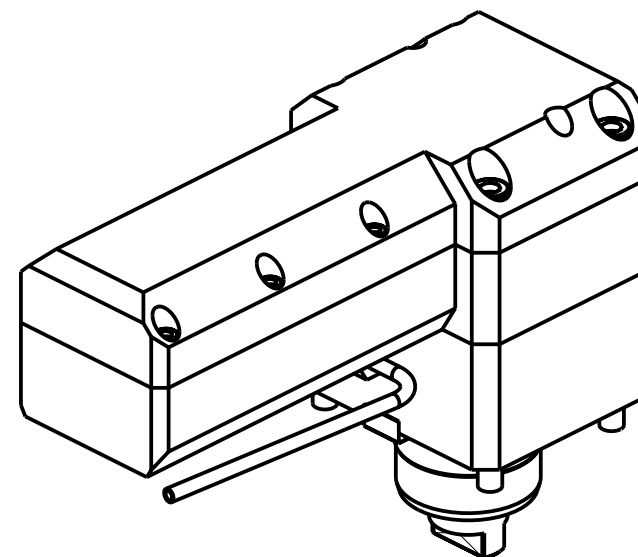

Cod. MT	Mandrino Spindle Spindel	I	RPM MAX	Coppia Max Max Torque Max Drehmoment	Lubrificazione est. Ext. coolant Aussenkuehlung	CHIAVI NON INCLUSE Keys not included Schluessel nicht einbegriffen	
TKW 0790325	ERA25	1:1	3500	60Nm	X	CHUB27	CHUB42

TAKISAWA

MOD: NEX315/715 - LS800M - VTL750/760M - LA350/450M - LA250YS 12ST. - NX2500 12ST.

MODULO MOTORIZZATO RADIALE ROVESCiato DISASSATO IN Z 180mm

Radial inverted driven tool re-directed in Z by 180mm

Radial angetriebenes Werkzeug umgedreht achsversetzt in Z um 180mm

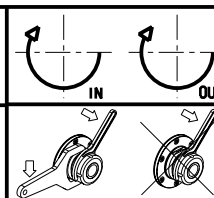

**M.T. srl**

Via Casino Albini 480  
Tel. 0541/956034-957884  
Fax 0541/956341

47842 S. GIOVANNI IN M. (RN)  
e-mail: mtma@mtmarchetti.com  
http://www.mtmarchetti.com



TKW 120-4-10

Subject to change without notice.

09/2024