

Ø16  
TOOL DIAMETER

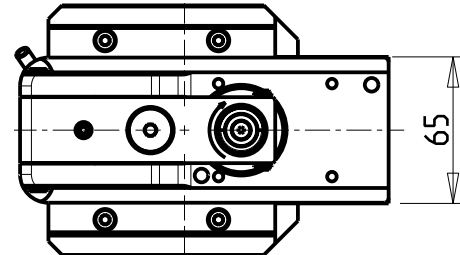
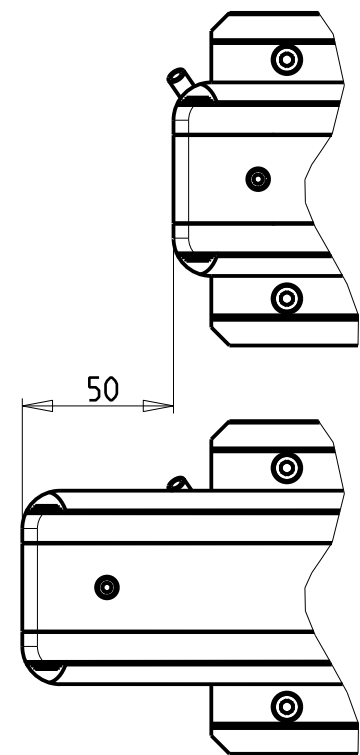
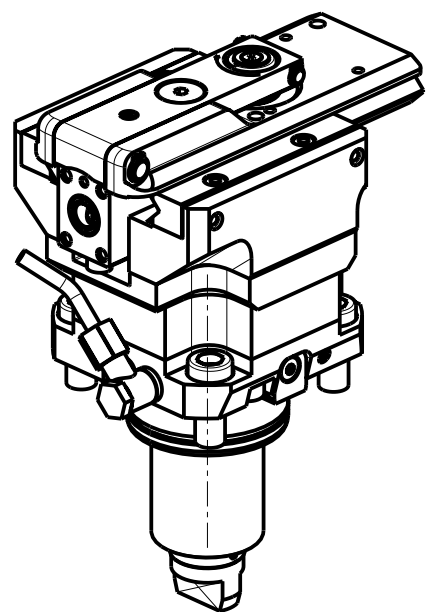

**DOTAZIONI - SUPPLIED WITH - AUSSTATTUNG**

N\*1 Boccia di riduz. Ø16-Ø12 e N\*1 Boccia di riduz. Ø16-Ø10  
 N\*1 Reduction bush Ø16-Ø12 and N\*1 Reduction bush Ø16-Ø10  
 N\*1 Reduzierbuchsen Ø16-Ø12 und N\*1 Reduzierbuchsen Ø16-Ø10

PER UTENSILI STOZZATORI VEDI PAG. TBL400-1-00  
 FOR DRIVEN SLOTTING TOOL CUTTING-TOOLS SEE PAGE TBL400-1-00  
 FÜR NUTENSTOSS-WERKZEUG SCHNEIDWERKZEUGE SIEHE SEITE TBL400-1-00

Cod. MT	I	RPM MAX	Reversibile lato mandrino/contromandrino Reversible sub/main spindle side Umkehrbare Spindel-seite/ Gegenspindel-seite	Lubr. esterna Ext. coolant Aussenkuehlung
DW 01530100	4:1	2000	X	X

**SPINNER**  
 MOD: TC800 SMCY (BMT65)  
 MODULO MOTORIZZATO STOZZATORE CORSA 50mm H=85mm  
 Slotting driven tool 50mm stroke H=85mm  
 Keilnutenstossmaschine 50mm Hub H=85mm

**M.T. srl**  
 Via Casino Albini 480  
 Tel. 0541/956034-957884  
 Fax 0541/956341  
 47842 S. GIOVANNI IN M. (RN)  
 e-mail: mtma@mtmarchetti.com  
 http://www.mtmarchetti.com



PAGINA SPN360-2-00

Subject to change without notice.