

ATTENZIONE - ATTENTION - ACHTUNG

- VERIFICARE LE MISURE DI INGOMBRO PER POSSIBILE INTERFERENZA SU ALCUNI MODELLI DI MACCHINE
- Please check the overall sizes for possible interferences on some machine models
- Bitte überprüfen sie das ausmass um mögliche interferenzen auf einigen maschinen modellen zu vermeiden

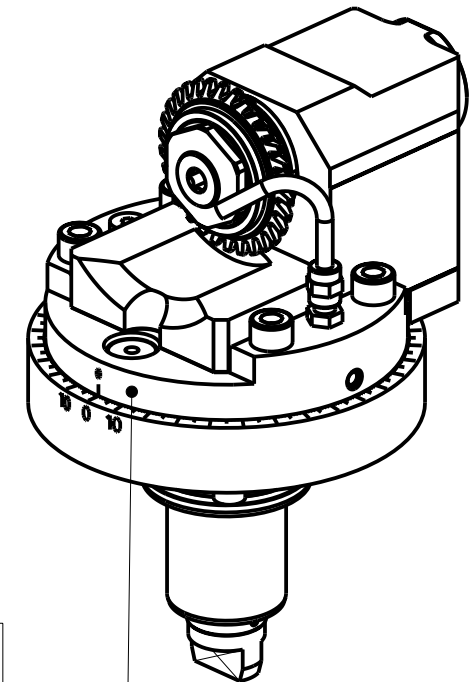
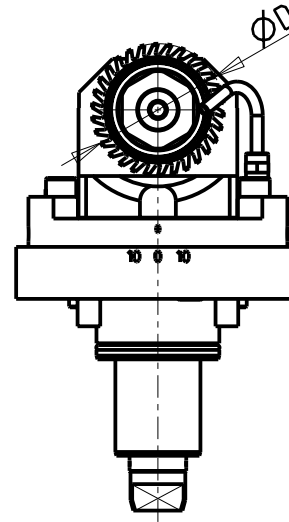
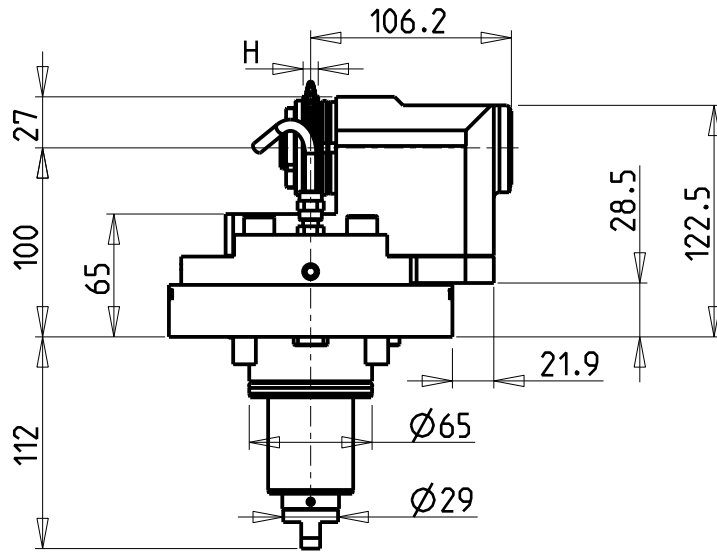
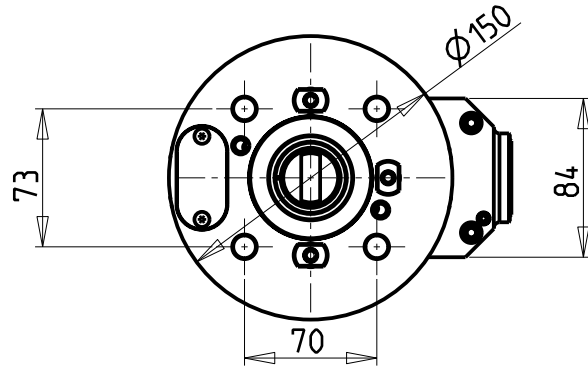

ORIENTABILE DI 360°

Cod. MT	Mandrino Spindle Spindel	I	RPM	Coppia Max Max Torque Max Drehmoment	Reversibile lato mandrino/contromandrino Reversible sub/main spindle side Umkehrbare Spindel-seite/ Gegenspindel-seite	Lubrificazione est. Ext. coolant Aussenkuehlung	ØD	H	CHIAVI INCLUSE Keys included Schluessel einbegriffen	
DW 02928022	Ø22x12	1:1	6000	50Nm	X	X	63-70-80	MAX 12	CHUB38	CHESL08
DW 02928125	Ø1"x12	1:1	6000	50Nm	X	X	63-70-80	MAX 12	CHUB38	CHESL08

SPINNER
MOD: TC800 SMCY - TTS85/125 12ST. (BMT65)

MODULO MOTORIZZATO PER VITI SENZA FINE

Driven tool for worm screws

Angetriebenes Werkzeug für schrauben ohne ende

Subject to change without notice.

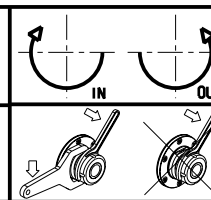

M.T. srl

Via Casino Albini 480
Tel. 0541/956034-957884
Fax 0541/956341
47842 S. GIOVANNI IN M. (RN)
e-mail: mtma@mtmarchetti.com
http://www.mtmarchetti.com



SPN359-2-00