



Plug Jet™



SCREW-IN, FLUSH MOUNT COOLANT NOZZLE

- Screws into an NPT or BSPT hole just like a flush plug
- 35 degrees adjustment either side of centerline
- Rated to 150 psi max
- Ideal for machining applications where nozzle projections must be minimized

DIMENSIONS IN INCHES

Part No.	Thread Size "E"	A	B(HEX)	C	Orifice Dia "d"	F(degrees)	Pkg Qty
PJ00510	1/8 NPT	.50	9/64	.12	.16	0-35	5
PJ00520	1/8 BSPT	.50	9/64	.12	.16	0-35	5
PJ00530	1/4 NPT/BSPT	.62	9/64	.15	.16	0-40	5
PJ00540	3/8 NPT/BSPT	.75	3/16	.18	.22	0-40	5

Material: Body - Acetal Ball - Stainless Steel

Maximum Operating Temperature: 160°F (70°C)

Maximum Pressure: 150 PSI (10 bar)

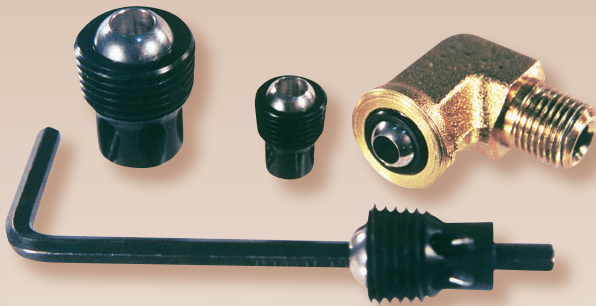
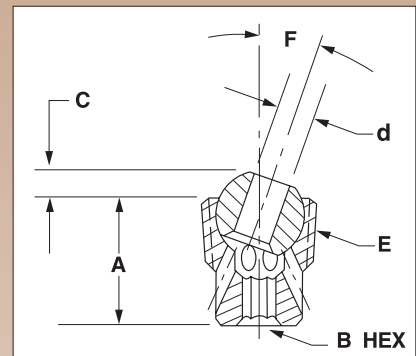

Simply insert the end of allen wrench (included) into the hole in the stainless ball until it engages the hex hole in the acetal body, then tighten the **PlugJet** into the tapped hole until the body is flush.

WE RESERVE THE RIGHT TO CHANGE SPECIFICATIONS WITHOUT NOTICE OR OBLIGATION.