

ATTENZIONE - ATTENTION - ACHTUNG

- Per lo smontaggio degli utensili utilizzare sempre la chiave di contrasto come indicato nel manuale d'uso.
- For disassembly of the tools use always the contrast key as mentioned in the user instructions.
- Fuer das Abmontieren der Werkzeuge immer den Gegenschlüssel benutzen wie in der Bedienungsanleitung erwaeht.

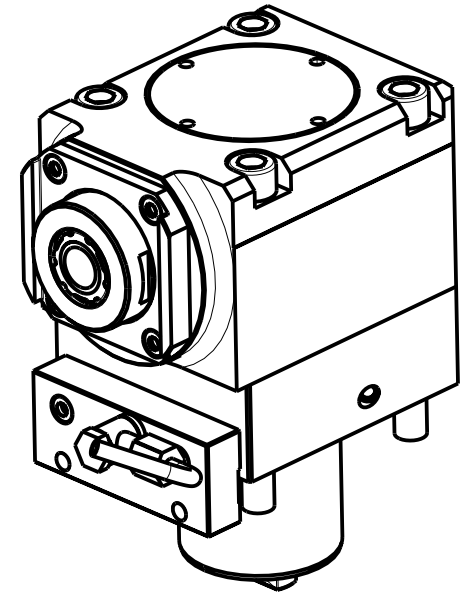

- Chiave inclusa
- Key included
- Schlüssel inbegriffen

Cod. MT	Mandrino Spindle Spindel	I	RPM	Coppia Max Max Torque Max Drehmoment	Reversibile lato mandrino/contromandrino Reversible sub/main spindle side Umkehrbare Spindel-seite/ Gegenspindel-seite	Lubrificazione int. Coolant through Innenkuehlung	Lubrificazione est. Ext. coolant Aussenkuehlung	B	CHIAVI NON INCLUSE Keys not included Schlüssel nicht einbegriffen		
OKU0470325	ERA25	1:2	12000	50Nm	X		X	64	CHUB27	CHTAER25ZC	OKU0650004
OKU0470425	ERA25	1:2	12000	50Nm	X	P=70bar	X	74	CHUB27	CHTAER25ZC	OKU0650004

OKUMA
MOD: LB4000EX(I) - LB4000EX(II) - LU4000EX

MODULO MOTORIZZATO ASSIALE MOLTIPLICATO I=1:2
 Axial geared-up I=1:2 driven tool
 Axial angetriebenes Werkzeug uebersetzt I=1:2

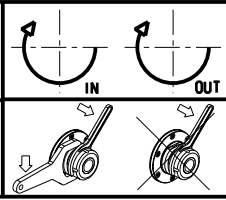

M.T. srl
 Via Casino Albini 480
 Tel. 0541/956034-957884
 Fax 0541/956341
 47842 S. GIOVANNI IN M. (RN)
 e-mail: mtma@mtmarchetti.com
 http://www.mtmarchetti.com



OKU200-5-10

Subject to change without notice.