

- Chiave inclusa
- Key included
- Schluessel inbegriffen

ATTENZIONE - ATTENTION - ACHTUNG

- Per lo smontaggio degli utensili utilizzare sempre la chiave di contrasto come indicato nel manuale d'uso.
- For disassembly of the tools use always the contrast key as mentioned in the user instructions.
- Fuer das Abmontieren der Werkzeuge immer den Gegenschluessel benutzen wie in der Bedienungsanleitung erwaehnt.

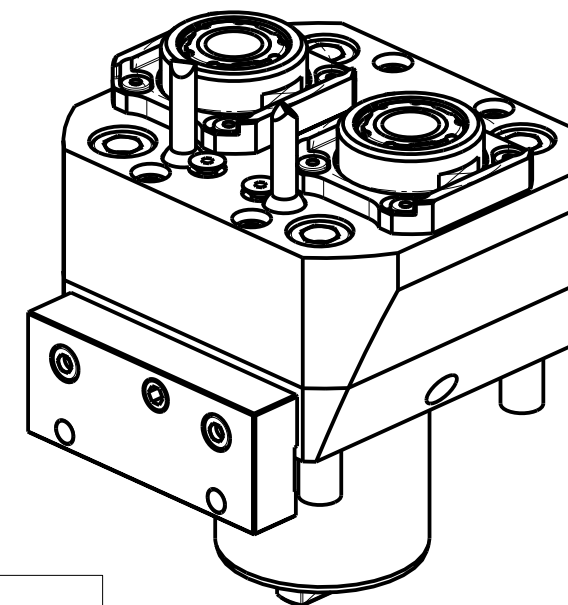

Cod. MT	Mandrino Spindle Spindel	I	RPM	Coppia Max Max Torque Max Drehmoment	Lubrificazione int. Coolant through Innenkuehlung	Lubrificazione est. Ext. coolant Aussenkuehlung	CHIAVI NON INCLUDE Keys not included Schluessel nicht inbegriffen		
OKU0450125	ERA25	1:1	6000	40Nm		X	CHUB27	CHTAER25ZC •	OKU0290009 •
OKU0450225	ERA25	1:1	6000	40Nm	P=70bar	X	CHUB27	CHTAER25ZC •	OKU0290009 •

OKUMA

MOD: LB4000EX(I) - LB4000EX(II) - LU4000EX

MODULO MOTORIZZATO RADIALE 2 USCITE IN Y

Radial single side twin head driven tool in Y

Radial angetriebenes Werkzeug 2 Ausgaenge in Y

Subject to change without notice.

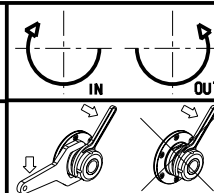

M.T. srl

Via Casino Albini 480
Tel. 0541/956034-957884
Fax 0541/956341
47842 S. GIOVANNI IN M. (RN)
e-mail: mtma@mtmarchetti.com
http://www.mtmarchetti.com



OKU080-5-00