

-Solo questa uscita è con lubrificazione interna.
 -Only this outlet is with internal coolant.
 -Nur dieser Ausgang ist mit IKZ.

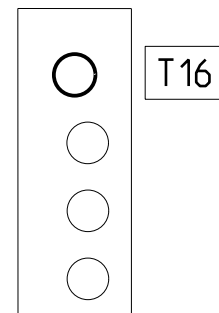
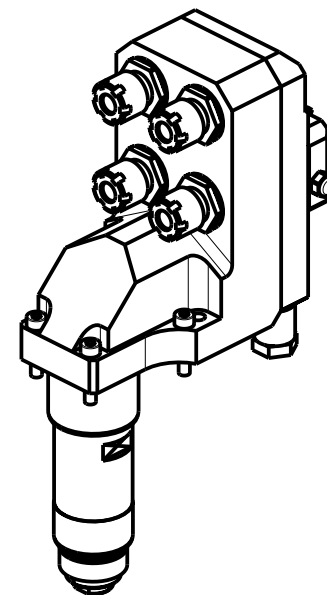
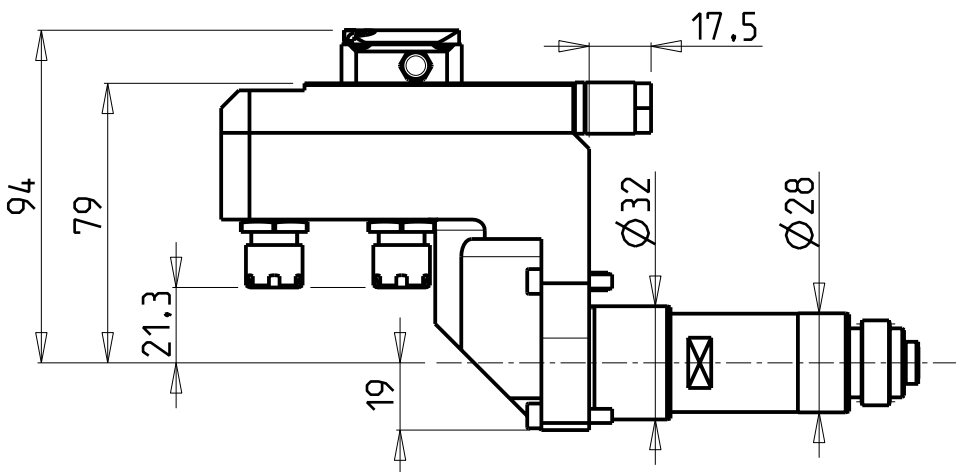
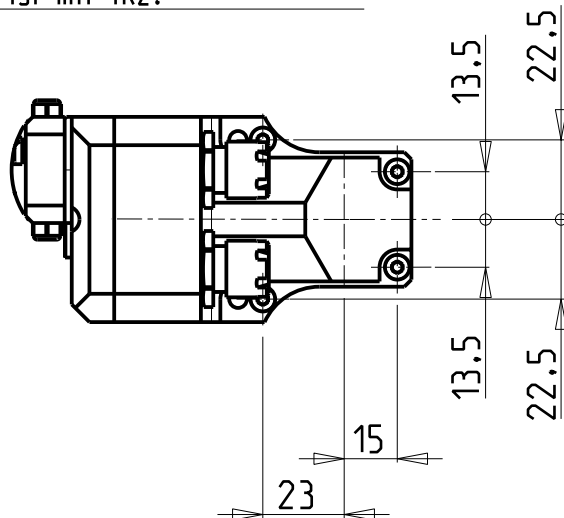

ATTENZIONE - ATTENTION - ACHTUNG

- Per lo smontaggio degli utensili utilizzare sempre la chiave di contrasto come indicato nel manuale d'uso.
- For disassembly of the tools use always the contrast key as mentioned in the user instructions.
- Fuer das Abmontieren der Werkzeuge immer den Gegenschlüssel benutzen wie in der Bedienungsanleitung erwaehnt.

Cod. MT	Mandrino Spindle Spindel	I	RPM	N°Utensili N°Tools N°Werkzeuge	Lubrificazione int. Coolant through Innenkuehlung	Lubr.esterna Ext. coolant Aussenkuehlung	CHIAVI NON INCLUDE Keys not included Schluessel nicht einbegriffen	
NMR0100111	ER11	1:2	12000	4	P=25bar	X	CHMNER11	CHUB19_SP3

NOMURA

MOD: NN20UB8 - NN25UB8 - NN20U5

MODULO MOTORIZZATO ASSIALE 4 USCITE MOLTIPLICATO I=1:2

Axial geared-up I=1:2 multiple 4 outlet driven tool

Axial angetriebenes Mehrspindel-Werkzeug 4 Ausgaenge uebersetzt I=1:2

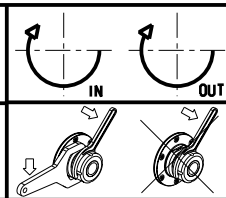

M.T. srl

Via Casino Albini 480
 Tel. 0541/956034-957884
 Fax 0541/956341

47842 S. GIOVANNI IN M. (RN)
 e-mail: mtma@mtmarchetti.com
 http://www.mtmarchetti.com



NOM271-3-00

Subject to change without notice.

03/2024