

ATTENZIONE - ATTENTION - ACHTUNG

- VERIFICARE LE MISURE DI INGOMBRO PER POSSIBILE INTERFERENZA SU ALCUNI MODELLI DI MACCHINE
- Please check the overall sizes for possible interferences on some machine models
- Bitte überprüfen sie das ausmass um mögliche interferenzen auf einigen maschinen modellen zu vermeiden

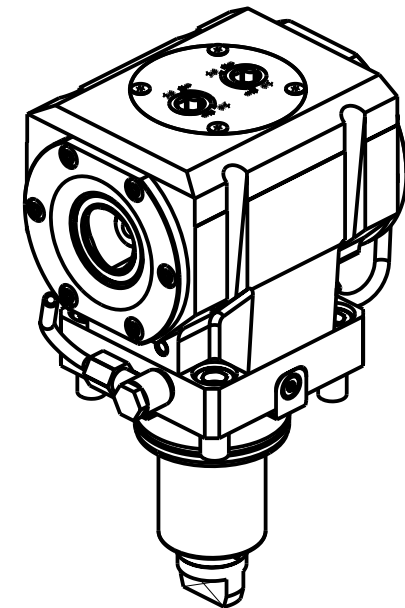

Cod. MT	TAGLIA Size Masse	I	RPM	Coppia Max Max Torque Max Drehmoment	Reversibile lato mandrino/contromandrino Reversible sub/main spindle side Umkehrbare Spindelseite/ Gegenspindelseite	Lubr.esterna Ext. coolant Aussenkuehlung
DW03140240	C4+C4	1:1	6000	100Nm	X	X

HAAS

MOD: ST20/25/28/30/35 (BMT65) - DS30 (BMT65)

MODULO MOTORIZZATO ASSIALE BISPORGENTE MT CAPTO H=85mm

Axial opposite face twin driven tool MT CAPTO H=85mm

Axial angetriebenes Werkzeug halb vorspringend mit MT CAPTO H=85mm

Subject to change without notice.

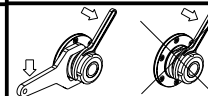

M.T. srl

Via Casino Albini 480
Tel. 0541/956034-957884
Fax 0541/956341
47842 S. GIOVANNI IN M. (RN)
e-mail: mtma@mtmarchetti.com
http://www.mtmarchetti.com



HAS240-D-41