

ATTENZIONE - ATTENTION - ACHTUNG

- VERIFICARE LE MISURE DI INGOMBRO PER POSSIBILE INTERFERENZA SU ALCUNI MODELLI DI MACCHINE
- Please check the overall sizes for possible interferences on some machine models
- Bitte überprüfen sie das ausmass um mögliche interferenzen auf einigen maschinen modellen zu vermeiden

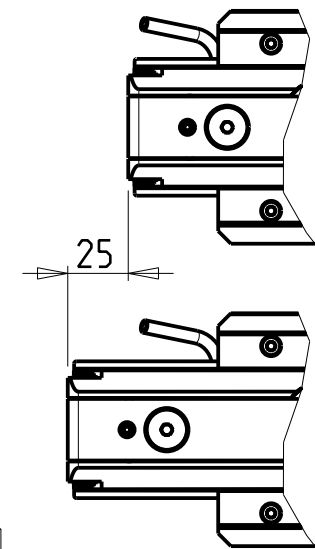

DOTAZIONI - SUPPLIED WITH - AUSSTATTUNG

N°1 Boccola di riduz. Ø16-Ø12 e N°1 Boccola di riduz. Ø16-Ø10
 N°1 Reduction bush Ø16-Ø12 and N°1 Reduction bush Ø16-Ø10
 N°1 Reduzierbuchsen Ø16-Ø12 und N°1 Reduzierbuchsen Ø16-Ø10

PER UTENSILI STOZZATORI VEDI PAG. TBL400-1-00
 FOR DRIVEN SLOTTING TOOL CUTTING-TOOLS SEE PAGE TBL400-1-00
 FÜR NUTENSTOSS-WERKZEUG SCHNEIDWERKZEUGE SIEHE SEITE TBL400-1-00

Cod. MT	I	RPM MAX	Lubr. esterna Ext. coolant Aussenkuehlung
MSL0460200	4:1	2400	X

GOODWAY
 MOD: GS200/230/260/280 - GA200/260/280 - GA2000/2600/2800/3000/3300/3600
 MODULO MOTORIZZATO STOZZATORE CORSA 25mm H=80mm
 Slotting driven tool 25mm stroke H=80mm
 Keilnutenstossmaschine 25mm Hub H=80mm

M.T. srl
 Via Casino Albini 480
 Tel. 0541/956034-957884
 Fax 0541/956341
 47842 S. GIOVANNI IN M. (RN)
 e-mail: mtma@mtmarchetti.com
 http://www.mtmarchetti.com

GDW 360-2-01

Subject to change without notice.