

ATTENZIONE - ATTENTION - ACHTUNG

- Per lo smontaggio degli utensili utilizzare sempre la chiave di contrasto come indicato nel manuale d'uso.
- For disassembly of the tools use always the contrast key as mentioned in the user instructions.
- Fuer das Abmontieren der Werkzeuge immer den Gegenschlüssel benutzen wie in der Bedienungsanleitung erwäehnt.

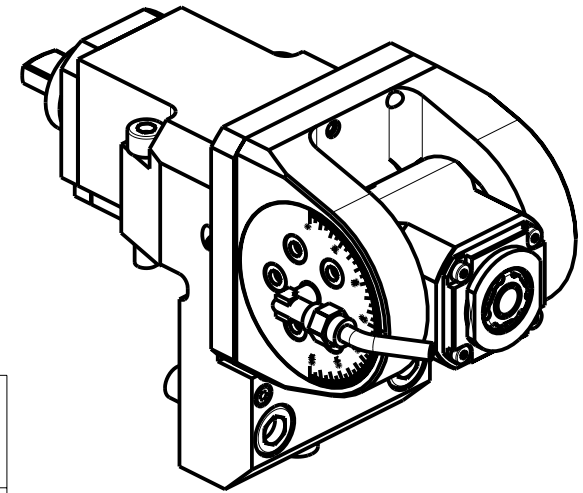

Non utilizzabile sulla torretta sinistra dei modelli DL15 e DL151 in quanto fuori volteggio
 Do not use on left turret of models DL15 and DL151. Out of max. dimensions of rotation!
 Nicht auf linken Revolver der Modelle DL15 und DL 151 benutzen. Sie befindet sich ausser Raumbedarf bei Drehung!

Cod. MT	Mandrino Spindle Spindel	I	RPM	Coppia Max Max Torque Max Drehmoment	Lubrificazione int. Coolant through Innenkuehlung	Lubrificazione est. Ext. coolant Aussenkuehlung	CHIAVI INCLUSE Keys included Schluesssel inbegriffen		
MSL0110316	ERA16	1:2	12000	8Nm		X	CHUB19_SP3	CHUB32	CHTAER16ZC
MSL0110416	ERA16	1:2	12000	8Nm	P=70bar	X	CHUB19_SP3	CHUB32	CHTAER16ZC

DMG-MORI
 SL-ZL150/153/154(MC-SMC-Y-SY) DL150MC DL15MC

MODULO MOTORIZZATO ORIENTABILE +/-90° MOLTIPLICATO I=1:2
 +/-90° adjustable angle driven tool geared-up I=1:2
 Angetriebenes Werkzeug schwenkbar +/-90° uebersetzt I=1:2

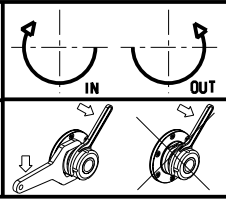

M.T. srl
 Via Casino Albini 480
 Tel. 0541/956034-957884
 Fax 0541/956341
 47842 S. GIOVANNI IN M. (RN)
 e-mail: mtma@mtmarchetti.com
 http://www.mtmarchetti.com



MSL336-1-00

Subject to change without notice.