

Ø16  
TOOL DIAMETER

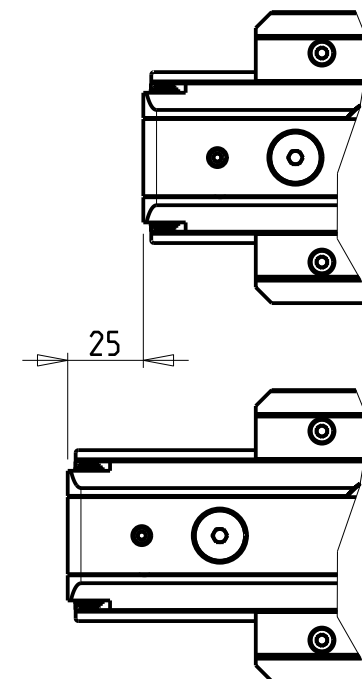
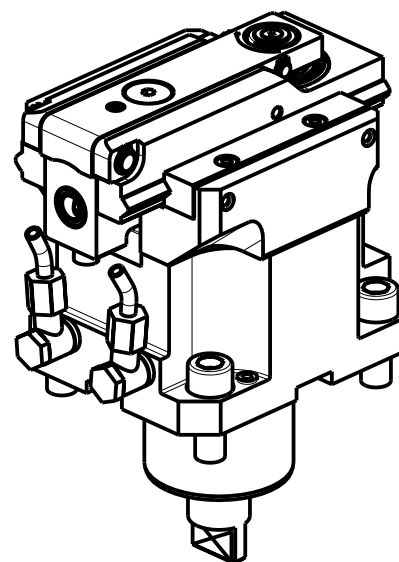

**DOTAZIONI - SUPPLIED WITH - AUSSTATTUNG**

N\*1 Boccola di riduz. Ø16-Ø12 e N\*1 Boccola di riduz. Ø16-Ø10  
 N\*1 Reduction bush Ø16-Ø12 and N\*1 Reduction bush Ø16-Ø10  
 N\*1 Reduzierbuchsen Ø16-Ø12 und N\*1 Reduzierbuchsen Ø16-Ø10

PER UTENSILI STOZZATORI VEDI PAG. TBL400-1-00  
 FOR DRIVEN SLOTTING TOOL CUTTING-TOOLS SEE PAGE TBL400-1-00  
 FÜR NUTENSTOSS-WERKZEUG SCHNEIDWERKZEUGE SIEHE SEITE TBL400-1-00

Cod. MT	I	RPM MAX	Reversibile lato mandrino/contromandrino Reversible sub/main spindle side Umkehrbare Spindelseite/ Gegenspindelseite	Lubr. esterna Ext. coolant Aussenkuehlung
MNL0650200	4:1	2400	X	X

**DMG-MORI**

NL1500/2000/2500/3000 12 STAZIONI - NLX1500/2000/2500/3000 12 STAZIONI - NLX4000 - NZL2000/2500 - NZX2500 (BMT60)  
 NT4200/4250/4300/5400 - NTX2000/2500/3000 2ND GEN. 10ST. - CTX2500 (BMT60)

MODULO MOTORIZZATO STOZZATORE CORSA 25mm H=94mm

Slotting driven tool 25mm stroke H=94mm

Keilnutenstossmaschine 25mm Hub H=94mm

Subject to change without notice.

**M.T. srl**

Via Casino Albini 480  
 Tel. 0541/956034-957884  
 Fax 0541/956341  
 47842 S. GIOVANNI IN M. (RN)  
 e-mail: mtma@mtmarchetti.com  
 http://www.mtmarchetti.com



MNL360-1-01