

**CUSCINETTI MAGGIORATI  
PER LAVORAZIONI PESANTI**

Reinforced bearings for heavy machining  
Vergroesserte Lager fuer schwerere Bearbeitungen

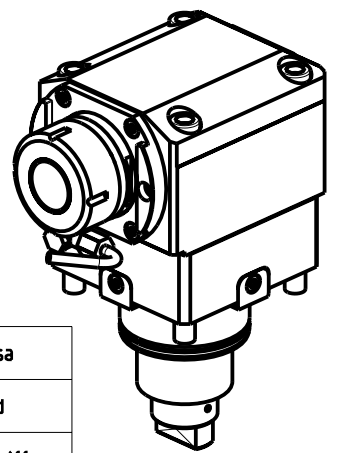

# ATTENZIONE: Non si monta su macchina V8300M  
# WARNING: This tool can not be mounted on V8300M  
# ACHTUNG: Werkzeug darf nicht auf V8300M montiert werden

- Chiave inclusa
- Key included
- Schluessel inbegriffen

Cod. MT	Mandrino Spindle Spindel	I	RPM	Coppia Max Max Torque Max Drehmoment	Reversibile lato mandrino/contromandrino Reversible sub/main spindle side Umkehrbare Spindel-seite/ Gegen-spindel-seite	Lubrificazione int. Coolant through Innenkuehlung	Lubrificazione est. Ext. coolant Aussenkuehlung	A	A1	A2	B	D	L	CHIAVI NON INCLUDE Keys not included Schluessel nicht einbegriffen	
DW 00650140	ER40	1:1	6000	140Nm	X	-	X	109.7	-	-	64	-	-	CHSTER40	OKU0430007 •
# DW 00650240	ER40	1:1	6000	140Nm	X	P=70bar	X	109.7	-	-	76.5	-	-	CHSTER40	OKU0430007 •
DW 00650725	WELDON 25	1:1	6000	140Nm	X	-	X	-	109.5	-	64	-	-	-	-
# DW 00650825	WELDON 25	1:1	6000	140Nm	X	P=70bar	X	-	109.5	-	76.5	-	-	-	-
DW 00650522	Ø22x19	1:1	6000	140Nm	X	-	X	-	-	89	64	22	19	CH_VTCROCE_M10 •	OKU0430007 •

DN SOLUTIONS (DOOSAN) BMT 75

MOD: PUMA 400 - PUMA 480M/LM/XLM - PUMA 4100M - PUMA 5100M/Y - V550M - VT 750M/TM - V8300M

MODULO MOTORIZZATO ASSIALE MAGGIORATO H=90mm  
Axial reinforced driven tool H=90mm  
Axial angetriebenes Werkzeug vergroessert H=90mm

Subject to change without notice.

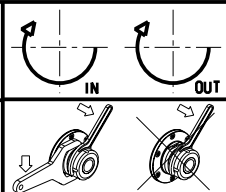

**M.T. srl**  
Via Casino Albini 480  
Tel. 0541/956034-957884  
Fax 0541/956341  
47842 S. GIOVANNI IN M. (RN)  
e-mail: mtma@mtmarchetti.com  
http://www.mtmarchetti.com



DW 0170-4-20