

CUSCINETTI MAGGIORATI PER LAVORAZIONI PESANTI

Reinforced bearings for
heavy machining

Vergroesserte Lager fuer
schwerere Bearbeitungen

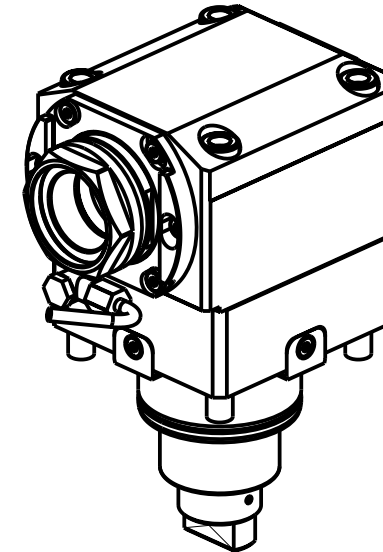

ATTENZIONE: Non si monta su macchina V8300M

WARNING: This tool can not be mounted on V8300M

ACHTUNG: Werkzeug darf nicht auf V8300M montiert werden

PER PORTAUTENSILI MODULARI MTSK-50 VEDI PAG. TBL300-1-50
FOR MTSK-50 QUIK CHANGE TOOLHOLDERS CLAMPINGS SEE PAGE TBL300-1-50
FUER MTSK-50 MODULARE WERKZEUGAUFNAHMEN SIEHE SEITE TBL300-1-50

Cod. MT	Mandrino Spindle Spindel	I	RPM	Coppia Max Max Torque Max Drehmoment	Reversibile lato mandrino/contromandrino Reversible sub/main spindle side Umkehrbare Spindel-seite/ Gegenspindel-seite	Lubr.interna Coolant through Innenkuehlung	Lubr.esterna Ext. coolant Aussenkuehlung	B	CHIAVI NON INCLUDE Keys not included Schluessel nicht einbegriffen	
DW02150150	MTSK-50	1:1	6000	140Nm	X	-	X	64	CHUB55	OKU0430007 •
# DW02150250	MTSK-50	1:1	6000	140Nm	X	P=70bar	X	76.5	CHUB55	OKU0430007 •

• Chiave inclusa

• Key included

• Schluessel inbegriffen

DN SOLUTIONS (DOOSAN) BMT 75

MOD: PUMA 400 - PUMA 480M/LM/XLM - PUMA 4100M - PUMA 5100M/Y - V550M - VT 750M/TM - V8300M

MODULO MOTORIZZATO ASSIALE MAGGIORATO MTSK H=90mm

Axial MTSK reinforced driven tool H=90mm

Axial MTSK angetriebenes Werkzeug vergroessert H=90mm

Subject to change without notice.

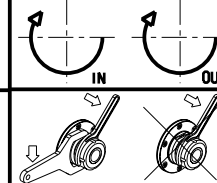

M.T. srl

Via Casino Albini 480
Tel. 0541/956034-957884
Fax 0541/956341

47842 S. GIOVANNI IN M. (RN)
e-mail: mtma@mtmarchetti.com
http://www.mtmarchetti.com



DW0170-4-20-K