

ATTENZIONE - ATTENTION - ACHTUNG

- VERIFICARE LE MISURE DI INGOMBRO PER POSSIBILE INTERFERENZA SU ALCUNI MODELLI DI MACCHINE
- Please check the overall sizes for possible interferences on some machine models
- Bitte überprüfen sie das ausmass um mögliche interferenzen auf einigen maschinen modellen zu vermeiden

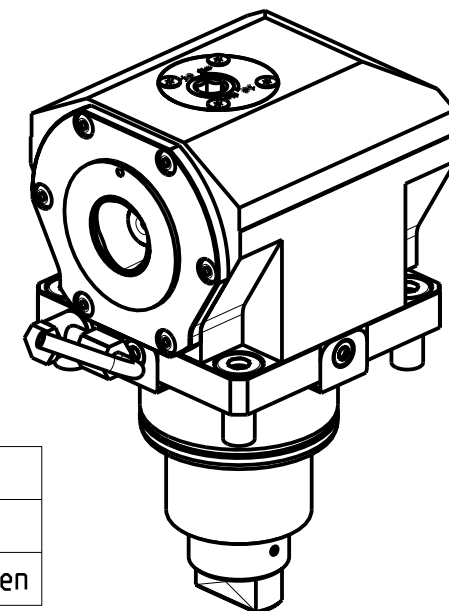

- # ATTENZIONE: Non si monta su macchina V8300M
- # WARNING: This tool can not be mounted on V8300M
- # ACHTUNG: Werkzeug darf nicht auf V8300M montiert werden

Cod. MT	TAGLIA Size Masse	I	RPM	Coppia Max Max Torque Max Drehmoment	Reversibile lato mandrino/contromandrino Reversible sub/main spindle side Umkehrbare Spindel-seite/ Gegenspindel-seite	Lubr.interna Coolant through Innenkuehlung	Lubr.esterna Ext. coolant Aussenkuehlung	L2
# DW00610140	C4	1:1	6000	140Nm	X	-	X	63
# DW00610240	C4	1:1	6000	140Nm	X	P=70bar	X	75.5
# DW00610150	C5	1:1	6000	140Nm	X	-	X	63
# DW00610250	C5	1:1	6000	140Nm	X	P=70bar	X	75.5

DN SOLUTIONS (DOOSAN) BMT 75

MOD: PUMA 400 - PUMA 480M/LM/XLM - PUMA 4100M - PUMA 5100M/Y - V550M - V8300M

MODULO MOTORIZZATO ASSIALE MT CAPTO H=60mm

Axial driven tool MT CAPTO H=60mm

Axial angetriebenes Werkzeug MT CAPTO H=60mm

Subject to change without notice.

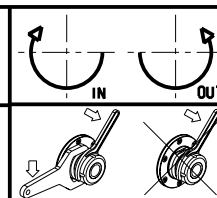

M.T. srl

Via Casino Albini 480
Tel. 0541/956034-957884
Fax 0541/956341
47842 S. GIOVANNI IN M. (RN)
e-mail: mtma@mtmarchetti.com
http://www.mtmarchetti.com



DW0150-D-40