

-COMPATIBILE CON UTENSILI COMMERCIALI AD INSERTI
 -COMPATIBLE WITH COMMERCIAL INSERT CUTTING-TOOLS
 -KOMPATIBEL MIT HANDELSÜBLICHEN SCHNEIDWERKZEUGEN

ATTENZIONE - ATTENTION - ACHTUNG

- VERIFICARE LE MISURE DI INGOMBRO PER POSSIBILE INTERFERENZA SU ALCUNI MODELLI DI MACCHINE
- Please check the overall sizes for possible interferences on some machine models
- Bitte überprüfen sie das ausmass um mögliche interferenzen auf einigen maschinen modellen zu vermeiden

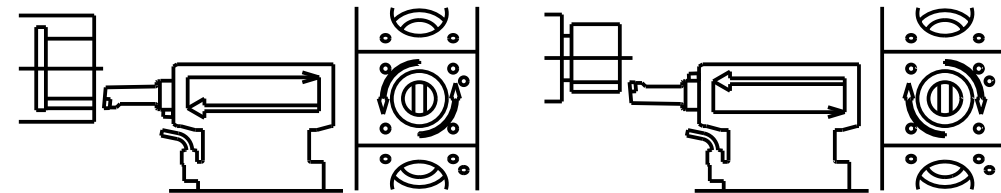
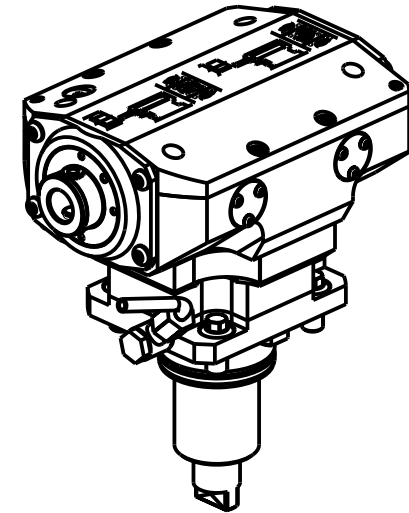
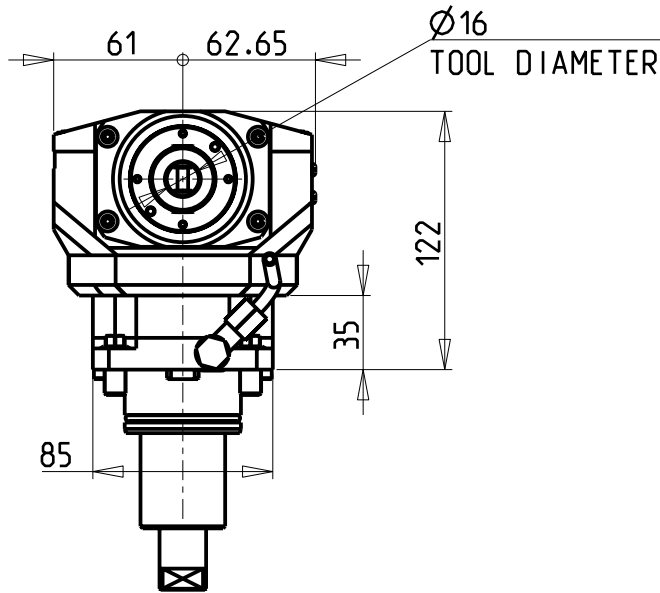
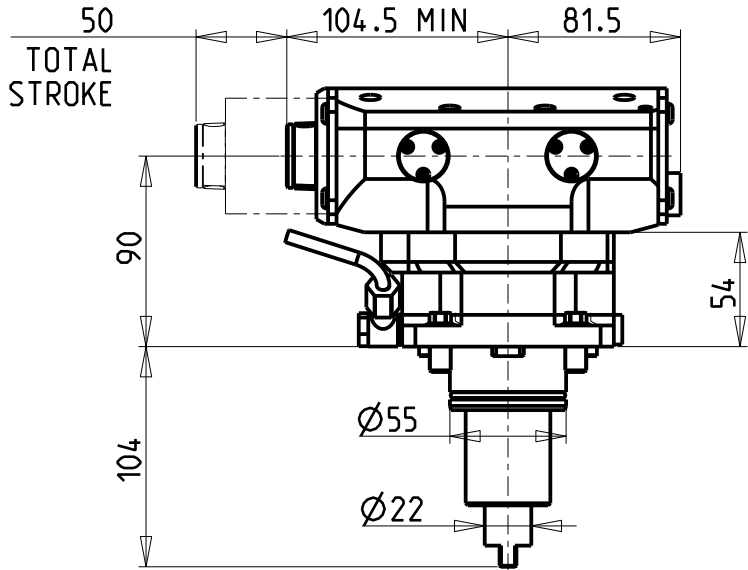
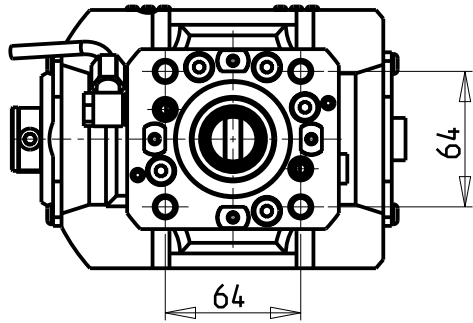

Cod. MT	I	RPM MAX	Reversibile lato mandrino/contromandrino Reversible sub/main spindle side Umkehrbare Spindelseite/ Gegenspindelseite	Lubr. esterna Ext. coolant Aussenkuehlung
DW 04 110100	1:1	500	X	X

DN SOLUTIONS (DOOSAN) BMT 55

MOD: PUMA 240M/MS-280LM - PUMA 1500-2000-2100-2500-2600M/MS/Y/SY - LINX 300 M - PUMA H250TM
 PUMA TT1500-1800-2100MS/SY/SYY - PUMA TL2000-2500 (M) - MX1600/2100ST 12ST. - SMX2100ST - PUMA QL200HM - LYNX 2600 Y/SY 12ST./16ST.

MODULO MOTORIZZATO BROCCIAATORE CORSA 50mm H=90mm
 Driven Broaching Toolholder 50mm stroke H=90mm
 Angetriebenes Nutzenstoßwerkzeug 50mm Hub H=90mm

M.T. srl

Via Casino Albini 480
 Tel. 0541/956034-957884
 Fax 0541/956341
 47842 S. GIOVANNI IN M. (RN)
 e-mail: mtma@mtmarchetti.com
 http://www.mtmarchetti.com



DW 0360-2-50

Subject to change without notice.