

ATTENZIONE - ATTENTION - ACHTUNG

- VERIFICARE LE MISURE DI INGOMBRO PER POSSIBILE INTERFERENZA SU ALCUNI MODELLI DI MACCHINE
- Please check the overall sizes for possible interferences on some machine models
- Bitte überprüfen sie das ausmass um mögliche interferenzen auf einigen maschinen modellen zu vermeiden

ATTENZIONE - ATTENTION - ACHTUNG

- Per lo smontaggio degli utensili utilizzare sempre la chiave di contrasto come indicato nel manuale d'uso.
- For disassembly of the tools use always the contrast key as mentioned in the user instructions.
- Für das Abmontieren der Werkzeuge immer den Gegenschlüssel benutzen wie in der Bedienungsanleitung erwähnt.

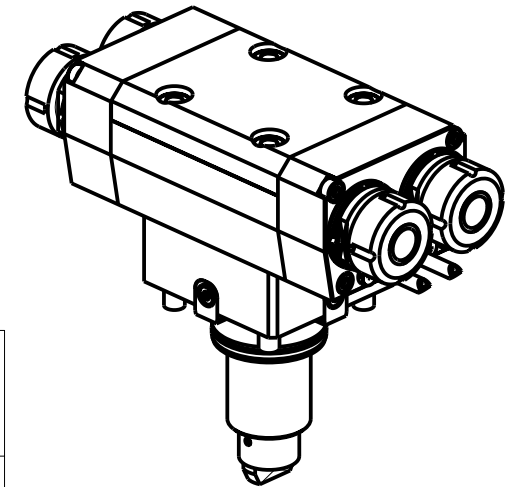

| Cod. MT | Mandrino Spindle Spindel | I | RPM | Coppia Max Max Torque Max Drehmoment | Reversibile lato mandrino/contromandrino Reversible sub/main spindle side Umkehrbare Spindel-seite/Gegenspindel-seite | N°Utensili N°Tools N°Werkzeuge | Lubrificazione est. Ext. coolant Aussenkuehlung | A | B | CHIAVI NON INCLUSE Keys not included Schluessel nicht einbegriffen | |
|-------------|--------------------------|-----|------|--------------------------------------|---|--------------------------------|---|-------|-------|--|----------|
| DW 02400416 | ER16+ER16 | 1:1 | 6000 | 50Nm | X | 2+2 | X | 114.7 | 120.7 | CHUB17 | CHMNER16 |
| DW 02400425 | ER25+ER25 | 1:1 | 6000 | 50Nm | X | 2+2 | X | 115.6 | 121.6 | CHUB36 | CHSTER25 |

DN SOLUTIONS (DOOSAN) BMT 55

MOD: PUMA 1500-2000-2100-2500-2600M/MS/Y/SY - PUMA 2100-2600Y/SY 16ST. - LYNX 2600 Y/SY 12ST./16ST.

MODULO MOTORIZZATO ASSIALE 2+2 USCITE IN Y H=70mm

Axial multiple 2+2 outlet driven tool in Y H=70mm

Axial angetriebenes Mehrspindel-Werkzeug 2+2 Ausgaenge in Y H=70mm

Subject to change without notice.

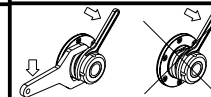

M.T. srl

Via Casino Albini 480
Tel. 0541/956034-957884
Fax 0541/956341
47842 S. GIOVANNI IN M. (RN)
e-mail: mtma@mtmarchetti.com
http://www.mtmarchetti.com



DW 0268-2-20