

**ATTENZIONE - ATTENTION - ACHTUNG**

- Per lo smontaggio degli utensili utilizzare sempre la chiave di contrasto come indicato nel manuale d'uso.
- For disassembly of the tools use always the contrast key as mentioned in the user instructions.
- Fuer das Abmontieren der Werkzeuge immer den Gegenschlüssel benutzen wie in der Bedienungsanleitung erwaeht.

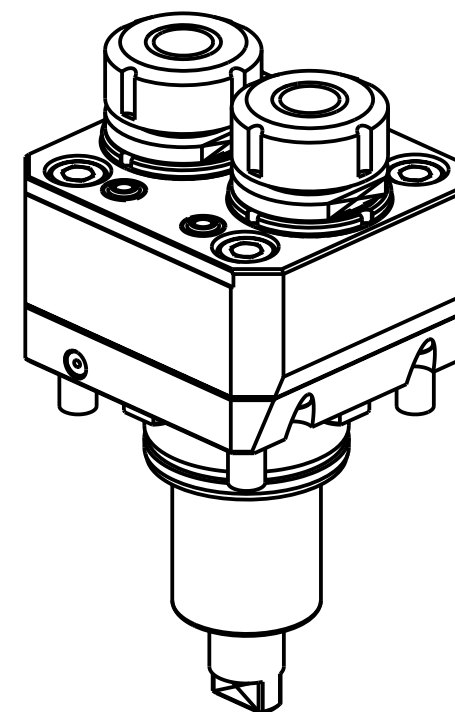
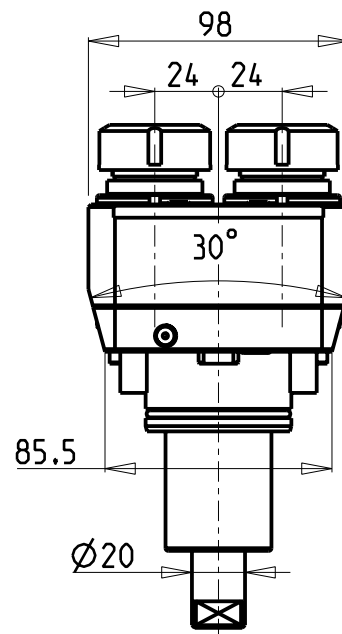
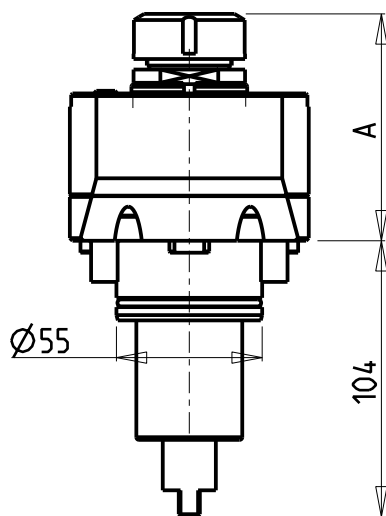
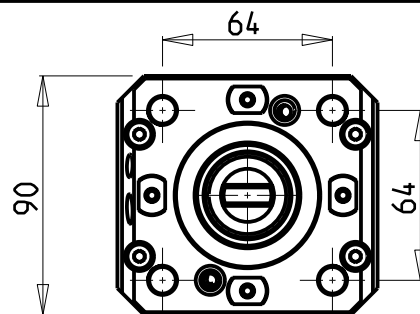

Cod. MT	Mandrino Spindle Spindel	I	RPM	Coppia Max Max Torque Max Drehmoment	Lubrificazione est. Ext. coolant Aussenkuehlung	A	CHIAVI NON INCLUSE Keys not included Schlüssel nicht einbegriffen	
0730016X2	ER16	1:1	6000	30Nm	X	84.5	CHMNER16	CHUB17
0730025X2	ER25	1:1	6000	30Nm	X	85	CHSTER25	MNLO210007

**DN SOLUTIONS (DOOSAN) BMT 55**

MOD: PUMA 1500-2000-2100-2500-2600M/MS/Y/SY - PUMA TT1500-1800-2100MS/SY/SYY - PUMA TL2000-2500 (M) LYNX 2600 Y/SY 12ST.

MODULO MOTORIZZATO RADIALE 2 USCITE IN Y  
Radial single side twin head driven tool in Y  
Radial angetriebenes Werkzeug 2 Ausgaenge in Y

Subject to change without notice.

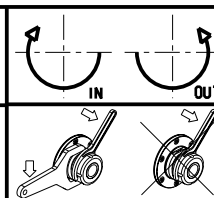

**M.T. srl**

Via Casino Albini 480  
Tel. 0541/956034-957884  
Fax 0541/956341  
47842 S. GIOVANNI IN M. (RN)  
e-mail: mtma@mtmarchetti.com  
http://www.mtmarchetti.com



DW 0080-2-00